

LCEKNX BOARD INSTALLATION

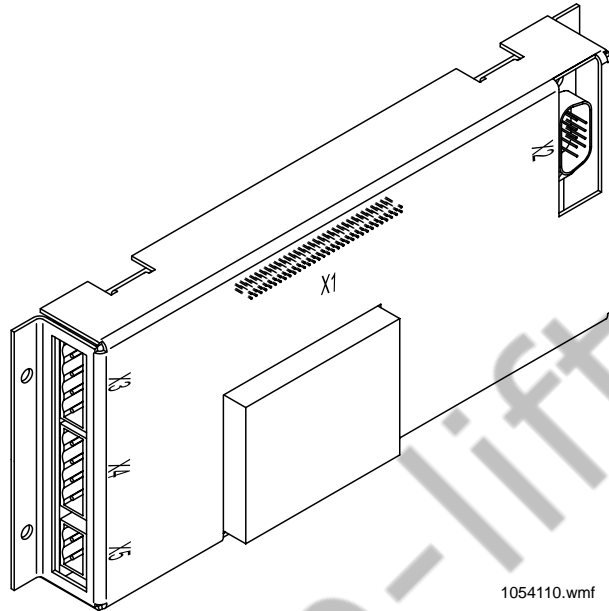

Table of contents

Authorization notice	2
Disclaimer of warranties and liabilities	2
General	3
Safety	3
LCEKNX board installation	4
Appendix 1 – Basic parameters	6
Appendix 2 – Advanced parameters	10
Appendix 3 – LCE fault codes	47

Authorization notice

This publication is for informational purposes only. This document provides general level information on the installation of the LCEKNX board. All persons participating and using these instructions must be qualified and trained to perform such work. A specific risk assessment must always be conducted to identify and assess the hazards of the installation work before commencing the installation. The selection of the parameters as listed in Appendix 2 - Advanced Parameters must never be changed without support from KONE specialists due to safety related reasons and risks.

Disclaimer of warranties and liabilities

KONE reserves the right at any time to alter the procedures reflected in this document. NO STATEMENT CONTAINED IN THIS DOCUMENT IS TO BE CONSTRUED AS A WARRANTY OR CONDITION, EXPRESS OR IMPLIED, AS TO ANY PRODUCT, SPECIFICATION OR PROCEDURE, ITS MERCHANTABILITY OR FITNESS FOR ANY PARTICULAR PURPOSE OR QUALITY, OR AS A MODIFICATION OR REPRESENTATION OF THE TERMS OF ANY PURCHASE AGREEMENT. KONE DISCLAIMS ANY LIABILITY RESULTING FROM OR IN CONNECTION WITH THE USE OF THE LCEKNX BOARD OR THE USE OR DISCLOSURE OF INFORMATION IN THIS DOCUMENT. KONE HAS NO LIABILITY FOR TYPOGRAPHICAL OR OTHER ERRORS OR OMISSIONS CONTAINED IN THIS DOCUMENT OR ANYONE'S INTERPRETATION OF THE INSTRUCTIONS. THE USER OF THE LCEKNX BOARD AND/OR OF THIS DOCUMENT ASSUMES ALL RISKS ASSOCIATED WITH SUCH USE OR WITH THE DISCLOSURE OF THIS DOCUMENT.

KONE, MonoSpace, MiniSpace, EcoDisc, TranSys, Alta, KoneXion, KONE ECO3000 and all other product names are trademarks or registered trademarks of KONE Corporation in various countries.

Copyright © 2007 KONE Corporation

All rights reserved. No part of the contents of this document may be copied, reproduced or transmitted in any form or by any means, or translated into another language or format, in whole or part, without prior written permission of KONE Corporation.

General

This instruction is a guideline for installing LCEKNX board KM713130G01 to LCECPU board for existing KONE MonoSpace, MiniSpace, TranSys Elevators and ReSolve Control System. The fitting of the LCEKNX will allow access to Control Parameters and Fault Codes via the LCE user interface. A list of Fault Codes and Control Parameters can be found in Appendices 1-3. The selection of the parameters as listed in Appendix 2 (Advanced Parameters) must never be changed without support from KONE specialists due to safety related reasons and risks.

For technical assistance with respect to the installation of the KNX card please contact your Regional KONE Office. For contact details, see www.kone.com

Safety

- When making electrical connections, the power must be turned OFF.
- Do not work on live equipment. Ensure that all electrical energy sources are identified and disconnected including the elevator's main switch, lighting switches, auxiliary supplies, emergency batteries and emergency generators.
- The car light is normally controlled by the main switch. This circuit has a separate switch.

The following 5 steps must be taken in the specified order unless there are essential reasons for doing otherwise.

Take 5 steps to ensure electrical safety:

1. Disconnect the power supply completely.
 2. Secure it against reconnection.
 3. Verify that the installation is de-energised.
 4. Check requirements for earthing in special circumstances. (This operation may only be carried out by qualified personnel, in co-operation with the person responsible for the building electrification who must ensure that the technique can be safely employed in this situation.)
 5. Provide protection against adjacent live parts.
- When working on the car roof and underneath the car, ensure that the elevator is safely isolated and cannot move. When working alone ensure that arrangements have been made to periodically monitor you welfare.
 - This installation takes place in occupied buildings. During the installation special care must be taken not to cause danger or unnecessary disturbance to the users of the building.
 - When working in the elevator shaft and it is necessary to keep the landing door open, protect the working areas on the landings so that other building users cannot come into contact with elevator equipment. Use additional safety fences or guarding.
 - If you have to keep the door open, park the car roof at the same landing level. Never leave the work place unattended when the elevator shaft is open.
 - Place warning notices and notices informing the public about the planned work.
 - Agree with the building owner about the working times so that the work does not unnecessarily disturb the inhabitants.
 - Ensure that communication is working both between fitters and between the fitters and other people in the building. Use warning and information signs, 2-way radios and liaison with the main contractor or building owner.

LCEKNX board installation

Step	Action	Note
1	Switch off the main power from the control panel.	
2	Mount the LCEKNX board (713130 G01) by pushing it carefully to connector X1 of the LCECPU board (A) or mount it on the LCECAN board (B).	<p style="text-align: right;">1054111.wmf</p>
3	Fix the LCEKNX board with four screws. If the LCEKNX board is upside down the screws do not fit.	
4	Connect plug XC20 (on the travelling cable) to the connector X5 on LCEKNX board.	<p style="text-align: right;">1054112.wmf</p>

<p>5</p>	<p>Connect the cable between the base unit and the LCEKNX board. If this is a group elevator, connect the cables between LCEKNX boards. A = base unit B = LCEKNX board C = LCEKNX board at the second elevator (group elevator)</p>	<p>1054113.wmf</p>
<p>6 7</p>	<p>Switch on the main power.</p> <p>Parameters and Fault Codes can be accessed via the LCE User Interface.</p> <p>For list of LCE Parameters and Fault Codes please refer to:</p> <ul style="list-style-type: none"> • Appendix 1 - Basic Parameters • Appendix 2 - Advanced Parameters • Appendix 3 - LCE Fault Codes 	<p>1054126.wmf</p> <ol style="list-style-type: none"> 1. Menu display 2. Sub menu display 3. Value display 4. Value setting button 5. Menu button 6. Select/Accept button

Appendix 1 – Basic parameters

List adapted from LCE User Interface Menu (Drawing No. 813131 Version 6.71)

For technical assistance please contact your Regional KONE Office. For contact details, see www.kone.com

Key for Default Values: * Default, Min or Max value not applicable, ** Min/Max floor number depends on shaft configuration (lowest floor, highest floor, Max Floors)

E	Fault log	Function	De- fault EU	De- fault NA	De- fault NC	Min	Max	Values	Description
	1	Fault history	*	*	*	*	*	1=latest fault	Scroll fault history with arrow buttons.
	2	Clear fault history	*	*	*	0	1	Set to 1 to clear fault history	Clear fault history from "E-menu".

1	Elevator parameters	Function	De- fault EU	De- fault NA	De- fault NC	Min	Max	Values	Description
Compulsory	Door	1	1	1	1	**	**	Floor number	Select the main entrance floor. Important for down collective control where collection of landing calls is towards main floor.
		10	5	5	5	1	60	1 .. 60 seconds, 1 second steps	Door hold open time for car call and landing call.
		11	20	20	20	1	99	0.1 .. 9.9 seconds, 0.1 second steps	Door hold open time for door open button. E.g. 20 = 2.0 seconds.
13	Nudging in use	1	4	0	0	4	0=OFF, 1=ON, 2=NUD L, 3=NUD AU, 4=NUD NA	If the doors are prevented from closing for the Nudging limit time, a buzzer in COP will sound and the doors will start to close at a reduced speed. This function overrides door open button (not for NA) and Photocell/Curtain Of Light. For NA, DOB will re-open the closing door. If NUD L is chosen and load > 60% the time is 5 seconds.	
14	Nudging limit	20	20	20	10	59	10 .. 59 seconds, 1 second steps	Time limit to activate Nudging function.	
15	Quick close with new car call		0	0	0	99	0.0=not in use, 0.1 .. 9.9 seconds, 0.1second steps	When doors are opening or opened, the hold open time can be reduced by entering a new car call including the floor where the elevator is standing. E.g.. 1.0=reducing time to 1.0 seconds.	

1	Elevator parameters	Function	De- fault EU	De- fault NA	De- fault NC	Min	Max	Values	Description
		16 Photocell delay	20	20	20	0	99	0.0 .. 9.9 seconds, 0.1 second steps	Guaranteed remaining door hold open time after Photocell / Curtain Of Light break.
		17 Quick close by photocell	1	1	1	0	1	0=OFF, 1=ON	Photocell / Curtain Of Light is allowed to shorten the door hold open time to Photocell delay (menu 1-16) value.
		25 Door opening time	20	20	20	0	99	0-9.9 seconds, 0.1 second steps	Door opening time at full speed when door type is timer control.
		26 Door closing time	20	20	20	0	99	0-9.9 seconds, 0.1 second steps	Door closing time at full speed when door type is timer control.
	Parking	30 Parking floor	0	0	0	0	**	0 or floor number from lowest floor to highest floor	If group parking is selected (menu 1-33) then this parameter value for Lift 1 is primary parking floor (PAM) and this value for Lift 2 is secondary parking floor (PAS) of group control. This should be zero for Lift 3 and also for Lift 2 if PAS is not wanted.
		31 Door open during parking	0	0	0	0	3	0=off, 1=A-door first, 2=B-door first, 3=both doors open	Door function during parking.
		32 Parking delay	30	30	30	1	99	1 .. 99 seconds, 1 second steps	Time that elevator has to be vacant before it can be parked.

3	Floor markings	Function	De- fault EU	De- fault NA	De- fault NC	Min	Max	Values	Description
		1 Seven segment symbols [1 .. 63]	*	*	*	*	*	0123456789ACEFHJLPU-	Change seven segment floor character symbols on Car Position Indicator. Symbols are shown on LCECPU display. Settings may change if menu 3-2 is used.
		2 Display code numbers [1 .. 63]	*	*	*	0	255	Display code value 0 .. 255	Used with Dot Matrix or LCD display. Changes numerical values of symbols. Letters and numbers have correct ASCII values. Settings may change if menu 3-1 is used. Contains display code numbers 1st, 2nd and 3rd character. 3rd char uses two blinking dots on segments 4 and 5.

4	Displays	Function	De- fault EU	De- fault NA	De- fault NC	Min	Max	Values	Description
	10	LCE CPU Software release number	*	*	*	*	*	Scrolling ASCII string. Example: "813140 6.0.4"	Scrolling display of elevator software drawing number and version.
	11	V3F Software release number	*	*	*	*	*	Form XX.YY (major.minor)	Displays V3F drive software version. Note! V3F16L, see Menu 6 V3F parameter manual.
	12	User interface menu version	6.72	6.72	6.72	*	*	Form XX.YY (major.minor)	Displays menu table version. Display value must be same as default field of this line of printed menu table.
	13	LCE CAN Software release number	*	*	*	*	*	Scrolling ASCII string. Example: "824555 1.0.8"	Scrolling display of CAN software drawing number and version.
	14	PC Group Software release number	*	*	*	*	*	Scrolling ASCII string. Example: "4.1.0.4"	Scrolling display of PC Group software version number.
	15	KRM Analyzer Software release number	*	*	*	*	*	Form XX.YY (major.minor)	Displays KRM Analyzer software version number.
	60	Display Elevators in LON network	*	*	*	*	*	Scrolling ASCII string. Example: "1 2 3 4 5 6 7 8"	Displays Elevators which are seen in LON network through GTW boards
	61	Display Elevators in CAN network	*	*	*	*	*	Scrolling ASCII string. Example: "1 2 3 4 5 6 7 8"	Displays Elevators which are seen in common memory CAN network

5	Commencing	Function	De- fault EU	De- fault NA	De- fault NC	Min	Max	Values	Description
	1	LWD Adjustment	*	*	*	*	*	% of capacity	Displays elevator load in percents. Use for Load Weighing Device (LWD) adjustments.
	2	Shaft setup	*	*	*	0	1	1=start setup drive	Elevator must be at lowest floor, 61:U ON. Turn RDF (pos.270) ON. Activate setup drive by changing value of menu 5-2 from 0 to 1 and press Select/Accept button, then turn RDF OFF.
	3	KoneXion Interface Card	1	1	1	1	3	1=LCEVOI, 2=LCEADJ, 3=LCEKNX	Select installed KoneXion card. This setting cannot be changed back to lower value. Must be set at the end of commencing!

7	Elevator parameters	Function	De-fault EU	De-fault NA	De-fault NC	Min	Max	Values	Description
		LDG Door Time Add	1	1	1	0	60	seconds [0..60]	Additional door open time for landing calls
		Main Floor Time Add	0	0	0	0	60	seconds [0..60]	Additional door open time at main entrance floor
		Buzzer Volume Main	7	0	7	0	10	0=OFF, 1 - 10=volume levels	Call button buzzer volume at main floor. For ROW, set to 0 if not KSS signalization. In North America DO NOT change from 0.
		Gong Volume	3	3	3	0	10	0=OFF, 1 - 10=volume levels	Gong volume
		Gong Volume Main	7	7	7	0	10	0=OFF, 1 - 10=volume levels	Gong volume at main floor
		Car Position Triggering	0	0	0	0	1	0=display advance position 1=display actual position	Landing and car displays show either advanced position or actual position.

Appendix 2 – Advanced parameters

NOTE: The selection of the advanced parameters must never be changed without support from KONE specialists due to safety related reasons and risks.

For technical assistance please contact your Regional KONE Office. For contact details, see www.kone.com

List adapted from LCE User Interface Menu (Drawing No. 813131 Version 6.71)

Key for Default Values: * Default, Min or Max value not applicable, ** Min/Max floor number depends on shaft configuration (lowest floor, highest floor, Max Floors).

1	Elevator parameters	Function	De-fault EU	De-fault NA	De-fault NC	Min	Max	Values	Description
	2	Control mode	3	3	2	1	6	1=SBC, 2=DC, 3=FC, 4=PB, 5=MPB, 6=FC with DIA	Call collection method. SBC=Single Button Collective, DC=Down Collective, FC=Full Collective, PB=Push Button, MPB=Memory Push Button.
	3	Hydraulic selection	0	0	0	0	7	0=none 1=KCM831 Hydro 2=hyd with anticreep 3=hyd + CLH 4=hyd with anticreep + CLH 5=KCM831 Hydro with telescopic jacks 6=KCM831 Hydro with PPS 7=KCM831 Hydro with telescopic jacks + PPS	0=no hydraulic control 1=Hydraulic w/o mechanical anticreep 2=Hydraulic with mechanical anticreep 3=Hydraulic w/o mechanical anticreep and with Cylinder Limit Switch 4=Hydraulic with mechanical anticreep and Cylinder Limit Switch 5=Hydraulic w/o mechanical anticreep and with telescopic jacks 6=Hydraulic w/o mechanical anticreep and with Positive Pressure switch 7=Hydraulic w/o mechanical anticreep and with Positive Pressure switch and telescopic jacks See ADON setup guide 805463.
	4	PIN code in use	0	0	0	0	1	0=PIN code not in use 1=PIN code in use	Enables or disables the PIN code features.

Elevator parameters	Function	De-fault EU	De-fault NA	De-fault NC	Min	Max	Values	Description
1	PIN Code Activated Features and Car Call PIN Code Locking (PCL) Setup	0	0	0	0	304	<p>UI Range 0 to 99 0=Setup of PCL and PIN codes accepted 1=Define floors of locked group 1 2=Define floors of locked group 2 ... 63=Define floors of locked group 63 ----- UI Range 100's 1-00=Reset (clear) all locked groups 1-01=Reset (clear) locked group 1 1-02=Reset (clear) locked group 2 ... 1-63=Reset (clear) locked group 63 ----- UI Range 200's 2-00=Set PIN code for Master group 2-01=Set PIN code for group 1 2-02=Set PIN code for group 2 ... 2-63=Set PIN code for group 63 ----- UI Range 300's Set PIN code for PIN activated features: 3-01=PRC 3-02=OSS 3-03=OCL 3-04=OCV</p>	<p>UI Range 0 to 99 Define the floors that are members of each PIN code locked group.</p> <p>UI Range 100's Clear the floors that were set via 1-5-1 to 1-5-63. Individual groups can be cleared, or all groups can be cleared at one time.</p> <p>UI Range 200's Program the PIN code for the locked groups that can be deactivated via a PIN code entry on the COP. Only available if menu item 1-4 = 1.</p> <p>UI Range 300's Program the PIN code for the features that can be activated/deactivated via a PIN code entry on the COP. Only available if menu item 1-4 = 1.</p> <p>Notes: 1) Elevator must be in RDF (machine room inspection) when this is changed.</p>

1	Elevator parameters	Function	De-fault EU	De-fault NA	De-fault NC	Min	Max	Values	Description
6	Security	Lockings Overridden	*	*	*	1	4	submenu 1 = lockings overridden by PRC submenu 2 = lockings overridden by PRL H / HEL submenu 3 = lockings overridden by PRL L submenu 4 = lockings overridden by ATS	Defines which options can override lockings
			8	8	8	1	59	seconds	Time the passenger has to enter the security code after a car call has been pushed. (Integrated Access)
			0	0	0	0	2	0 = OFF 1 = Integrated Access (IAC) 2 = High Level Security Interface (HLI)	Enable/disable Access Control
			0	0	0	0	2	0 = operative (DOB disabled at locked floor) 1 = operative under LOC too 2 = operative under LOC if once opened	Enables / disables locked door reopen
12	Door	Select ADO, ACL and correction drive	1	1	1	0	7	0=no ADO, ACL, COD (E-line) 1=ADO, ACL, COD (E-line) 2=no ADO, no ACL, no COD (1-speed) 3=ADO, no ACL, no COD (Hyd 300, anticreep) 4=ADO, no ACL, COD (Hyd 300S) 5=ADO, ACL, no COD (Hyd 300, ADO) 6=no ADO, ACL, no COD (Hyd 300, no ADO) 7=no ADO, no ACL, COD (Hyd 300S, no ADO)	ADO=Advanced Door Opening. This can be used to disable ADO when LCEADO board is used for releveling doors open (ACL B). Correction drive is prohibited with 1 speed drive and Hyd 300.
			1	4	0	0	4	0=OFF, 1=ON, 2=NUD L, 3=NUD AU, 4=NUD NA	If the doors are prevented from closing for the Nudging limit time, a buzzer in COP will sound and the doors will start to close at a reduced speed. This function overrides door open button (not for NA) and Photocell/Curtain Of Light. For NA, DOB will re-open the closing door. If NUD L is chosen and load > 60% the time is 5 seconds.
			1	4	0	0	4	0=OFF, 1=ON, 2=NUD L, 3=NUD AU, 4=NUD NA	

1	Elevator parameters	Function	De-fault EU	De-fault NA	De-fault NC	Min	Max	Values	Description
15		Quick close with new car call	0	0	0	0	99	0,0=not in use, 0.1 .. 9.9 seconds, 0.1second steps	When doors are opening or opened, the hold open time can be reduced by entering a new car call including the floor where the elevator is standing. E.g.. 1.0=reducing time to 1.0 seconds.
16		Photocell delay	20	20	20	0	99	0.0 .. 9.9 seconds, 0.1second steps	Guaranteed remaining door hold open time after Photocell / Curtain Of Light break.
17		Quick close by photocell	1	1	1	0	1	0=OFF, 1=ON	Photocell / Curtain Of Light is allowed to shorten the door hold open time to Photocell delay (menu 1-16) value.
18		Simultaneous door opening forbidden	3	3	3	1	3	1=A-door first, 2=B-door first, 3=simultaneous opening	TTC CTF function. Should be used only with locking of calls.
20		Door buzzer	0	0	0	0	3	0=OFF, 1=ON, 2=CGM I, 3=DOI	GOH IT function for handicapped people. When the door reaches open limit the COP buzzer sounds informing free pass for blind people.
21		Extended door reopen time	0	0	0	0	3	0=Button (DOE B), 1=Switch and buzzer (DOE SI), 2=Switch without buzzer (DOE S) 3=DOE T(DOE toggle for marine use)	DOE=Door reOpen with Extended time. LCECOB board (pos. 32) input XC17 (34:E).
22		DOP type	0	0	0	0	1	0=none, 1=DOP CS	Select DOP type.
23		Door type	1	1	1	0	16	0=none, 1=ADV(AMD), 2=continuous torque, 3=timer control, 4=swing + AMD, 5=swing+continuous torque, 6=swing+timer control, 7=swing, 8=swing+car Besam, 9=swing+automatic car Besam, 10=swing+landing Besam, 11=swing+automatic landing Besam, 12 = MAC, 13=GAL, 14=Freight doors (Peelle or Courion), 15=swing+MAC, 16=swing+GAL	Select front door type

1	Elevator parameters	Function	De-fault EU	De-fault NA	De-fault NC	Min	Max	Values	Description
37		Park area used	0	0	0	0	1	0=OFF, 1=ON	Enables or disables Park Area (PAR) feature. Also select group parking (menu 1-33=2).
		Park low limit floor	0	0	0	0	**	0=not in use, otherwise lowest floor of the park area	Select the lowest floor of the park area. Valid only if menu 1-37=1.
		Park high limit floor	0	0	0	0	**	0=not in use, otherwise highest floor of the park area	Select the highest floor of the park area. Valid only if menu 1-37=1.
Calls	40	Car calls backward	1	1	1	0	1	0=OFF, 1=ON	Elevator can accept car calls also behind travelling direction.
	41	False car call canceling	*	*	*	1	2	Submenu 1: [0,1,2,3,4]0=OFF, 1=FCC C, 2=FCC L, 3=FCC B, 4=FCC D Submenu 2: [0,1]0=OFF, 1=FCC R	FCC C = Car calls canceled after the car made a number of stops without interrupting the beam of the safety ray or curtain of light or without opening swing door, FCC L = Cancelling of car calls is based on measuring the load of the cars (less or equal 5%) and comparing it against the number of car calls entered, FCC B = Cancelling of car calls is based on the load or passengers cutting the safety ray, FCC D = Cancelling of false destination calls, FCC R = Cancellation of active car call .
42		Car call registered buzzer	0	0	0	0	1	0=OFF, 1=ON	Buzzer in COP will give short sound when car call is registered.
43		Landing call bypassing allowed	1	1	1	0	2	0=OFF, 1=use Timed Out Call 2=use Timed Out Call (no priority for FET/FEB calls)	Elevator can in certain conditions bypass a young landing call when serving old landing call. Improves traffic handling capacity.
44		Attendant service	0	0	0	0	5	0=No ATS, 1=normal ATS, 2=ATS HK, 4=ATS C, 5=ATS NA	Determines how attendant service station in COP is working.
45		Locking type	0	0	0	0	3	0=no locking, 1=car calls locked (LOC E), 2=landing calls locked (LOLE), 3=car and landing calls locked	Defines use of Locking Inputs on LCEOPT card.

1	Elevator parameters	Function	De-fault EU	De-fault NA	De-fault NC	Min	Max	Values	Description
1		46	0	0	0	0	**	Submenu 1: First selected floor for priority normal down call Submenu 2: Second selected floor for priority normal down call Submenu 3: Third selected floor for priority normal down call	PRA = Priority At Landing option. Defines max three floors for high priority normal down calls. 0=no floor, otherwise floor number for high priority call down
		47	0	0	0	0	**	Submenu 1: First selected floor for priority normal up call Submenu 2: Second selected floor for priority normal up call Submenu 3: Third selected floor for priority normal up call	PRA = Priority At Landing option. Defines max three floors for high priority normal up calls. 0=no floor, otherwise floor number for high priority call up
		48	1	1	1	0	2	0= Calls cancelled at stopping 1= Calls cancelled at deceleration point 2= Car calls cancelled at deceleration point	Defines cancelling calls. With automatic doors calls are cancelled at deceleration point. With swing doors or automatic+swing doors calls are cancelled at stopping.
		49	5	5	5	0	59	seconds	Time to transfer hall call to another elevator after failing
		50	1	1	1	1	8	Elevator number	Must be 1 or 2 in Duplex elevators, and 1, 2 or 3 in Triplex.
		51	33	33	33	21	64	Elevator number in E-link and PC group communication	Each elevator connected to E-link (33-64) or PC group (21-30) must have different node number.
		52	0	0	0	0	8	0=KoneXion not activated 1 .. 8=Elevator number	Each elevator connected to one KoneXion Base Unit must have different KoneXion elevator number.
		53	1	1	1	0	3	0=no reopening, 1=one opening, 2=several openings, 3=REO HK	Selects how many time a landing call can reopen the door of the elevator which has car calls.
		54	1	1	1	1	**	Floor number. Shaft setup must be done after changing lowest floor !	FEB * option. Should be used only in elevator groups where one or more elevators reach a lower floor than the bottom floor of the group. Elevator must be at bottom floor and in RDF when this is changed. Those of menu 1 submenus 30, 34, 35, 59, 64 and 89 that have non-zero value lower than new lowest floor will be changed to be the same as the new lowest floor !

1	Elevator parameters	Function	De-fault EU	De-fault NA	De-fault NC	Min	Max	Values	Description
		55 Group ID for E-link	0	0	0	0	32	Group number = 0, 2, 4, 6, etc..	Selects group number for E-link. All elevator groups connected to E-link system (even in different workstations) must have unique Group ID number. Use even numbers 0, 2, 4, 6, ... only.
		56 Group size	8	8	4	1	8	Group size	Group size the lift is member in
		58 Group Type	0	0	0	0	1	0 = Embedded group interface 1 = PC group interface	Defines group control type
	Fire	59 Fire reserve floor	0	2	0	0	**	0 or floor number from lowest floor to highest floor	Fire reserve floor. Must be zero with FID B and FID M.
		60 Recall floor	1	1	1	**	**	Floor number	Fire Detection (FID) and Fireman's Drive (FRD) phase one return floor. Note: EN81-72 uses parameter 7.55 to define FRD return floor.
		61 Area code	0	23	0	0	26	0=not in use, 1=DE, 2=CS, 3=BE, 5=FR, 6=UK N, 7=NL, 8=UK S, 10=SE, 11=HK, 12=AU, 13=AE, 14=MY, 15=SG, 16=IN, 17=AP, 18=SA, 19=TW, 20=NZ, 21=L NZ, 22=CA, 23=US, 24=EN81-72, 25=EN81-72 Car sw, 26=KR	1=Germany, 2=Russia, 3=Belgium, 5=France, 6=United Kingdom normal, 7=Holland, 8=United Kingdom firefighting, 10=Sweden, 11=Hong Kong, 12=Australia, 13=United Arab Emirates, 14=Malaysia, 15=Singapore, 16=Indonesia, 17=Asian Pacific, 18=Saudi Arabia, 19=Taiwan, 20=New Zealand, 21=New Zealand lockout, 22 = Canada, 23 = USA, 24=EN81-72, 25=EN81-72 with in car switch, 26 = Korea
		62 Type	0	1	0	0	13	0=none, 1=FRD, 2=FID BCI, 3=FID BOI, 4=FID BCI + FRD, 5=FID BOI + FRD, 6=FID MCI, 7=FID MOI, 8=FID MCI + FRD, 9=FID MOI + FRD, 10=FID ACI, 11=FID AOI, 12=FID ACI + FRD, 13=FID AOI + FRD	Defines if there is FID, FRD or FID + FRD.
		63 Door opening side during fire detection	1	1	1	1	4	1=A-door+A-door, 2=B-door+A-door 3=A-door+B-door, 4=B-door+B-door	Defines how doors of main return floor and alternative return floor will stay after FID or FRD phase one return drive. Note: EN81-72 uses parameter 7.56 to define FRD return side.

1	Elevator parameters	Function	De-fault EU	De-fault NA	De-fault NC	Min	Max	Values	Description
Emergency	64	Emergency drive destination floor	0	0	0	0	**	0=next possible floor, otherwise floor number from lowest floor to highest floor	EPD = Emergency Power Drive option. Defines EPD function return floor. EPD can be activated LCEOPT board pos 722:1 input X5/4. If MARINE Settings is valid this parameter is SSM return floor for marine area.
	65	Door position after emergency drive	0	0	0	0	3	0=doors closed, 1=A-door open, 2=B-door open, 3=both doors open	Defines how door will stay after Emergency Power Drive return drive.
	66	Fire protection door	0	0	0	0	2	0=no FPD, 1=FPD *O, 2=FPD *T	FPD *O = Fire Protection Door, All floors / Specified floors, One landing is disconnected. FPD *S = Fire Protection Door, All floors / Specified floors, also landing below and above are disconnected. Fire Protection Door inputs (normally closed) on LCEOPT board pos. 722:8 - 722:B must be activated by this parameter.
Peak	67	Lifts to lobby	2	2	2	0	8	Number of lifts to return to the main floor during Up Peak	Defines the number of lifts to return to the main floor during Up Peak. Main floor is selected by menu 1-1 value
	68	Lifts to second lobby	0	0	0	0	8	Number of lifts to return to the second main floor during Up Peak	Defines the number of lifts to return to the second main floor during Up Peak. Second main floor is selected by menu 1-69 value
Misc.	69	Second Main floor	0	0	0	0	**	Floor number	Select the second main entrance floor
	70	Full load indication percentage	80	80	80	50	99	% of capacity	Full load % limit can be adjusted here. Does not effect to the overload limit (110%) and LWD potentiometer adjustments. Elevator bypasses landing calls when full load is on.
	71	Inspection drive limited	3	3	3	0	5	0=SED B, stop at 77:N(+77:S) and 77:U(+77:S), 1=SED T, stop at 77:U(+77:S), 2=SED P, stop at 77:N(+77:S), 3=SED W, stop at terminal floor (at least one 61 vane), 4=SED W + OTB AU A-side, 5=SED W + OTB AU B-side.	Inspection drive (car roof buttons) operation area can be limited by deceleration switches (pos. 77:U and 77:N). Inspection drive stops latest at the terminal floor level.
	72	Out of service recall floor	0	0	0	0	**	Switch in car: 0=nearest floor, 1... dedicated return floor Switch at landing: 0=switch location floor, 1... dedicated return floor	OSS=Out Of Service. If this parameter is zero then COP OSS key switch stops the elevator to nearest floor and landing OSS key switch returns elevator to the key switch location floor. Otherwise elevator returns to this floor by all OSS inputs. If MARINE Settings is valid this parameter is WSC M return floor for marine area.

1	Elevator parameters	Function	De-fault EU	De-fault NA	De-fault NC	Min	Max	Values	Description
73	Out of service door		0	0	0	0	3	0=doors closed, 1=A-door open, 2=B-door open, 3=both doors open	Door state after OSS recall function.
74	Priority landing call type		0	0	0	0	15	0=no PRL, 1=PRL LA, 2=PRL LO, 3=PRL HA, 4=PRL HO, 5=HEL AI, 6=HEL OI, 7 = HEL CI, 8=HEL CI + PRL LA, 9=HEL CI + PRL LO, 10=PRL HA + PRL LA, 11=PRL HA + PRL LO, 12=PRL HO + PRL LA, 13=PRL HO + PRL LO 14=HEL CI + PRL LA (with HEL override of PRC), 15=HEL CI + PRL LO,(with HEL override of PRC)	Defines the way how this elevator is serving Priority Landing calls (connected to LCEFOB).
75	Car fan saving		5	5	5	0	59	0 .. 59 minutes before shutting off, 1 minute increments.	Delay timer for car fan. Shuts off the fan after the car has been vacant and time is elapsed. See also parameter 1-92 Fan type.
76	Car light saving		5	5	5	0	59	0 .. 59 minutes before shutting off, 1 minute increments.	Delay timer for car light. Shuts off the car light after the car has been vacant and time is elapsed. See also parameter 1-98 Light Type
77	Car light voltage supervision		1	0	1	0	2	0=no CLS 1=CLS O (door parked open with CLS fault) 2=CLS C (door parked closed with CLS fault)	CLS option. Elevator will be stopped if car light voltage is missing on car roof board (LCECCB).
78	KoneXion car light current detector		0	0	0	0	1	0=OFF, 1=ON	Car light current detector is connected to KoneXion car unit.
79	Car light in OSS mode		1	1	1	0	1	0=OFF, 1=ON	Car light can be switched OFF in OSS mode. OSS car key switch can be used to close the elevator and shut the light.

1	Elevator parameters	Function	De-fault EU	De-fault NA	De-fault NC	Min	Max	Values	Description
80	Compulsory stopping at main floor	0	0	0	0	6	0=no stopping 1=down direction with normal operation 2=up direction with normal operation 3=both directions with normal operation 4=down direction with security door operation 5=up direction with security door operation 6=both directions with security door operation	CSM option. When driving past the main floor the elevator makes a normal stop to let a security guard to check the people inside the car. If TTC car then both doors are opened.	
81	Floor passing signal	0	1	0	0	2	0=OFF, 1=HAN C, 2=HAN B	HAN C and HAN B options. An audible floor passing buzzer signal in COP telling to the passengers that the car is either stopping or passing the floor. HAN C is active all the time. HAN B is activated for one travel at a time with KSS button in car.	
83	Flashing overload indicator	0	0	0	0	1	0=OFF, 1=ON	Overload indication in COP can be selected to be blinking.	
84	Priority car call type	1	34	1	1	50	1=Normal PRC (PRC K) 2=PRC with impulse and timer (PRC B) 3=Community of indep. states (PRC CS) 4=FSC AU and PRC K 5=PRC T flash card with 3min timeout 33 = Canada, 34 = USA, 50 = New Zealand	Priority Call in Car option. Activated by LCECOB board (pos. 32) input XC16 (35).	
85	Start Delay	0	0	0	0	254	0=PUD not in use, delay time in seconds	Power up loading of building power supply can be reduced. Elevator is starting after air conditioning devices etc.	
86	EAQ in use	0	0	0	0	1	0=EAQ not in use, 1=EAQ in use	EAQ = Earthquake option. EAQ inputs on LCEOPT board pos. 722:1 must be activated by this parameter.	
87	EBD in use	0	0	0	0	2	0=EBD not in use, 1=EBD in use, 2=UPS in use	EBD = Emergency Battery Drive. EBD function must be activated by this parameter. Not used in NA. Use parameter 7-51.	
88	FRE door	0	0	0	0	3	0=not in use, 1=A-door, 2=B-door, 3=both	FRE = Fast Recall. Defines which door will be opened after FRE switch is returned to the 'OFF' position.	

1	Elevator parameters	Function	De-fault EU	De-fault NA	De-fault NC	Min	Max	Values	Description
		89 FRE floor	0	0	0	0	**	0=not in use, otherwise floor number from lowest floor to highest floor	When FRE is activated by its LCEOPT board input, the elevator returns non-stop to the FRE return floor without opening its doors.
		90 Dual duplex control	0	0	0	0	3	0=not in use 1=serve all calls 2=do not serve normal calls on main floor 3=do not serve FET/FEB calls on main floor	Parameters are set to accept FET/FEB calls for two of the elevators and normal up/down calls are denied in main floor for the third elevator.
		91 DOM CS in use	0	0	0	0	3	0=DOM CS not in use, 1=DOM CS in use, 2=EBULI in use, 3=Automatic door EBULI	DOM CS = Door Open Monitoring option on or off. Ebulli configuration.
		92 FAN type	0	0	0	0	5	0 = OCV A-Automatic, no switch 1 = OCV AF-Automatic, switch to turn off 2 = OCV M -Manual 3 = OCV K -Button 4 = OCV P -Permanent On 5 = OCV I -Impulse	Defines operation of car ventilation. OCV A is for automatic control of the fan, with or without a switch. For OCV A and OCV AF, use 1-75 (Car Fan Saving) to set idle time for fan to turn off. If OLV N is required, set Light Type (1-98) and Fan Type (1-92) to a value of 0 (A). If OLV B is required, set Light Type (1-98) and Fan Type (1-92) to a value of 1 (AF).
		93 Non selective cop	0	0	0	0	2	0=not in use, 1=in use, 2=common car gong	Non selective car operating panel in case of through type car. LCECOB board for door side B is not needed. Both doors are working by LCECOB/side-A door buttons and car calls. Landing calls are still working in selective way. Value 2 is selective cop with common car gong in case of KSS one cop in through type car.

1	Elevator parameters	Function	De-fault EU	De-fault NA	De-fault NC	Min	Max	Values	Description
	94	GOC GONG selection	0	1	0	0	10	0 = GOC not in use, directional gong 1 = directional GOC, directional GONG 2 = GOC not in use, non directional GONG 3 = non directional GOC, non directional GONG 4 = GOC not in use, advanced directional GONG 5 = directional GOC, advanced directional GONG 6 = GOC not in use, advanced non directional GONG 7 = non directional GOC, advanced non directional GONG 8 = GOC not in use, GONG not in use 9 = directional GOC, GONG not in use 10 = non directional GOC, GONG not in use	Selection for car gong and gong at level
	95	Drive Interface	0	0	1	0	3	0 = Parallel interface in use (V3F18/V3F25) 1 = Serial communication interface in use (DCBH, MCU, V3F16L, V3F25S etc) 2 = LCEDRV board in use 3 = LCEDRV board in use + G13 OPT board I/O map for ReSolve 5"	0 = Parallel interface in use (V3F18/V3F25) 1 = Serial communication interface in use (DCBH, MCU, V3F16L, V3F25S etc) 2 = LCEDRV board in use 3 = LCEDRV board in use + G13 OPT board I/O map for ReSolve 5"
	96	OSI / HSL selection	0	0	0	0	2	0=OSI, 1=HSL, 2=Use up light as OSI A	OSI indication output in FCB and OPT G02 is used either as out of service indication or here signal light. 2 is possible only in PB and DC control modes.
	97	ACL Doors Open Allowed	1	1	1	0	1	0 = Releveling with doors closed 1 = Releveling with doors open or closed	Defines if releveling is done with doors open or closed

1	Elevator parameters	Function	De-fault EU	De-fault NA	De-fault NC	Min	Max	Values	Description
		98 Light Type	0	0	0	0	3	0=OCL A-Automatic, no switch 1=OCL AF-Automatic, switch to turn off 2=OCL M -Manual 3=OCL P -Permanent On	Defines operation of car lightning. OCL A is for automatic control of the light, with or without a switch. For OCL A and OCL AF, use 1-76 (Car Light Saving) to set idle time for lighting to turn off. If OLV N is required, set Light Type (1-98) and Fan Type (1-92) to a value of 0 (A). If OLV B is required, set Light Type (1-98) and Fan Type (1-92) to a value of 1 (AF).
	Default	99 Recall parameter defaults	*	*	*	0	2	Set to 1 to recall FACTORY defaults Set to 2 to recall EPROM defaults	Must be at 1st floor, (77N & 61U active) and in RDF mode! Value 1: copies FACTORY parameter default values to FIELD area. Value 2: clears NVRAM and copies EPROM parameter default values to FACTORY and FIELD areas. No effect to the drive parameters.

3	Floor markings	Function	De-fault EU	De-fault NA	De-fault NC	Min	Max	Values	Description
		3 Acoustic floor indicators [1 .. 63]	*	*	*	0	255	Acoustic message number	Select acoustic floor messages when ACU unit is connected.
		4 Acoustic announcements	1	1	1	0	3	0=floor and special announcements 1=also direction 2=also door movement 3=also direction and door movement	Use this when ACU unit is connected and direction and/or door movement announcements are required.
		5 LCD language 1 selection	6	34	6	0	39	0=none, 1=Arabic, 2=Chinese, 3=Czech, 4=Danish, 5=Dutch, 6=UK English, 7=Estonian, 8=Finnish, 9=Flamish, 10=French, 11=German, 12=Greek, 13=Hungarian, 14=Italian, 15=Japanese, 16=Korean, 17=Latin, 18=Latvian, 19=Lithuanian, 20=Norwegian, 21=Polish	Selects first language used by LCD displays.

3	Floor markings	Function	De-fault EU	De-fault NA	De-fault NC	Min	Max	Values	Description
		6	6	34	6	0	39	22=Portugal, 23=Portuguese, 24=Russian, 25=Slovak, 26=Spanish, 27=Swedish, 28=Turkish, 29=Catalan, 30=Icelandic, 31=Slovenian, 32=Austrian German, 33=Mainland Chinese, 34=NA English, 35=NA French, 36=Univ English, 37=Marine English, 38.39 not used	Selects second language used by LCD displays.
		7	*	*	*	0	255	Display code value 0 .. 255	Used with LCD display 3rd character. Changes numerical values of symbols. Letters and numbers have correct ASCII values. NOTE: Moved to menu 3-2. 3rd char uses two blinking dots on segments 4 and 5.

4 Displays	Function	De-fault EU	De-fault NA	De-fault NC	Min	Max	Values	Description
	DTS time	*	*	*	*	*	Time in seconds	Displays Drive Time Supervision (DTS) timer triggering value.
20							1=Run shaft end-to-end, 2=Run from lowest floor to 2 floors above lowest floor and back, 3=Random run all floors, 4=Continue random run after power break	Automatic landing call generator. Landing call buttons must be connected and working. Random run cycle has as many calls as there are floors, each floor is visited once before starting new cycle. Car Call Programming Sequence: 1) Set UI item 4-21-10. 2) Press and hold DOB for 2 seconds to begin the programming sequence. 3) Press and hold each car call button in the desired sequence for 2 seconds. 4) Press and hold DOB for 2 seconds to end the programming sequence. 5) Set UI item 4-21-9 to run this sequence. Example: run 1 to 3 to 1 to 6, and repeat. Press the DOB, 1, 3, 1, 6, DOB. A maximum of 20 calls can be in the sequence. Landing call disable from the CPU is recommended. To reprogram again, a power cycle is required!
21	Test run floors and doors	0	0	0	0	10	5=same as 1 with car calls 6=same as 2 with car calls 7=same as 3 with car calls 8=same as 4 with car calls 9=Run automatic car calls as defined in 4-21-10 (will continue after power break) 10=Program automatic car call sequence (sequence retained through power break)	
30	Display ADON Channel 1 Values	0	0	0	0	4	1=Current Speed 2=Peak Speed 3=Pulses/meter 4=Software Version	Motor Encoder Channel. (Used in NA only) 1 = Current Speed in cm/sec. 2 = Peak speed in cm/sec. of last run. 3 = Pulses per Meter of movement. 4 = This ADON Channel software version number.
31	Display ADON Channel 2 Values	0	0	0	0	4	1=Current Speed 2=Peak Speed 3=Pulses/meter 4=Software Version	Car Encoder Channel. (Used in NA only) 1 = Current Speed in cm/sec. 2 = Peak speed in cm/sec. of last run. 3 = Pulses per Meter of movement. 4 = This ADON Channel software version number.
40	Display NTS version	0	0	0	0	9999	NTS sw version in MCU board.	Displays The hardware & software versions of the software currently installed in the NTS board formatted as HW.SW (Not used in NC)

4 Displays	Function	De- fault EU	De- fault NA	De- fault NC	Min	Max	Values	Description
	50 Display ETSL Set Speed	0	0	0	0	127	Rotary switch setting of ETSL board. Tenths of m/sec. Submenu 1.1 = First board, car node. Submenu 1.2 = First board, motor node. Submenu 2.1 = Second board, car node. Submenu 2.2 = Second board, motor node. ... Depending on number of ETSL boards max. value 5.2	Displays the speed setting of the ETSL rotary switches formatted as ONES.TENTHS meters/second The display value omits the decimal point, so that the displayed value is in tenths of meters/second. Note: menu 5-51 sets these values. This menu only displays them. (Not used in NC) The display of the speed settings alternates with a neuron identification number x,y, where x is the board number & y is 1 for car neuron, or 2 for motor neuron. Examples of id numbers: 1.1 (first board, car neuron) 1.2 (first board, motor neuron) 2.1 (second board, car neuron)
	51 Display ETSL Error	0	0	0	0	0xffff	Current Error Code. Submenu 1.1 = First board, car node. Submenu 1.2 = First board, motor node. Submenu 2.1 = Second board, car node. Submenu 2.2 = Second board, motor node. ... depending on number of ETSL boards max. value 5.2	Displays the ETSL error bits from each neuron in hexadecimal format. Refer to the Software Specification document # 804441H01 for interpretation of the bits. The value is alternately displayed with the board-neuron id described in menu 4-50 (Not used in NC)
	52 Display ETSL Status	0	0	0	0	256	Current Value of Status Byte. Submenu 1.1 = First board, car node. Submenu 1.2 = First board, motor node. Submenu 2.1 = Second board, car node. Submenu 2.2 = Second board, motor node. ... depending on number of ETSL boards max. value 5.2	Displays the current value of the status bits from each neuron in hexadecimal format. Refer to the Software Specification document #804441H01 for interpretation of the bits. The value is alternately displayed with the board-neuron id described in menu 4-50 (Not used in NC)

4 Displays	Function	De-fault EU	De-fault NA	De-fault NC	Min	Max	Values	Description
53	Display ETSL scaling factor	0	0	0	0	9999	Current value of ETSL scaling factor - stored at setup. Submenu 1.1 = First board, car node. Submenu 1.2 = First board, motor node. Submenu 2.1 = Second board, car node. Submenu 2.2 = Second board, motor node. ... depending on number of ETSL boards max. value 5.2	Displays the current scaling factor in m/sec for each neuron. The value is alternately displayed with the board-neuron id described in menu 4-50. The scale factors are a ratio of the encoder inputs and the speed inputs, as such their values depend on the encoders used & the individual lift hardware. For a given lift, all etsl boards should share the same values of car scale factors and motor scale factors. (Not used in NC)
54	Display ETSL speed at last crossing	0	0	0	0	9999	m/sec speed reading. Submenu 1.1 = First board, car node. Submenu 1.2 = First board, motor node. Submenu 2.1 = Second board, car node. Submenu 2.2 = Second board, motor node. ... depending on number of ETSL boards max. value 5.2	Displays the car speed in m/sec recorded by each neuron at the last point that that neuron's position switches were tripped by the car's passage. The value is alternately displayed with the board-neuron id described in menu 4-50 (Not used in NC)
55	Display ETSL speed step max	0	0	0	0	9999	m/sec value stored in each etsl neuron. Submenu 1.1 = First board, car node. Submenu 1.2 = First board, motor node. Submenu 2.1 = Second board, car node. Submenu 2.2 = Second board, motor node. ... depending on number of ETSL boards max. value 5.2	Displays the maximum allowable difference in speed between the current reading and the previous reading in m/sec. If this limit is exceeded, the current speed reading will be replaced by a calculated value. The value is alternately displayed with the board-neuron id described in menu 4-50 (Not used in NC)

4	Displays	Function	De-fault EU	De-fault NA	De-fault NC	Min	Max	Values	Description
								ETSL sw version display. Submenu 1.1 = First board, car node. Submenu 1.2 = First board, motor node. Submenu 2.1 = Second board, car node. Submenu 2.2 = Second board, motor node. ... Depending on number of ETSL boards max. value 5.2	Displays the hardware & software versions of the software currently installed in the ETSL board, formatted as HW.SW The value is alternately displayed with the board-neuron id described in menu 4-50 (Not used in NC)
56	Display ETSL version	0	0	0	0	9999			

5	Commencing	Function	De-fault EU	De-fault NA	De-fault NC	Min	Max	Values	Description
4		Roll call direction	1	1	1	1	4	1=down 2=up (PU elevator) 3=old shaft bundle, OPTG02 supervised, OPTG02 outputs used for call lights 4=no supervision, no outputs for call lights	In PU elevators choose 2. Elevator must be at bottom floor and in RDF when this is changed. Note that XS1 connector on LCEFCB/FOB boards must be always towards control panel.
5		Learning mode	*	*	*	0	1	1=start learning mode	Elevator must be in RDF. Activate learning mode by changing value of menu 5-5 from 0 to 1 and press Select/Accept button, then turn RDF OFF. Not accessed with serial drive interface.
6		Fine floor adjustment	*	*	*	0	1	1=start fine floor adjustment	Activate fine floor adjustment by changing value of menu 5-6 from 0 to 1 and press Select/Accept button. Turn the elevator to RDF and then back to NORMAL to end this mode.
7		Lon download	*	*	*	0	2	1=download node if LCE has different version 2=force downloading of every node	Turn RDF (pos.270) ON. Activate lon download by changing value of menu 5-7 from 0 to 1 or 2 and press Select/Accept button.

5 Commencing	Function	De-faultEU	De-faultNA	De-faultNC	Min	Max	Values	Description
8	Landing/Car IO pairing	3	3	3	0	3	0=OFF 1=group IO pairing in FCB's and FOB's ON 2=local IO pairing in COB's ON 3=local and group IO pairing FCB's, FOB's and COB's ON	Sigma (old signalization) in landing and car = 0 Sigma (old signalization) in car only = 1 Sigma (old signalization) in landing only = 2 New signalization everywhere = 3
9	E.Brake Type	1	1	1	0	3	0 = No emergency brake supervisions 1 = Dual brake system. Second brake (e.brake) will be dropped after delay defined in 5-10 2 = Rope Gripper emergency brake 3 = Emergency brake always drops on Emergency Stop	If this parameter is changed, an ADON Learn (menu 5-25) must be performed. Used only in North American controllers with LCEADON board. See ADON setup guide 805463.
10	E.Brake Hold Time	30	30	30	2	255	Time in seconds	Emergency brake will be dropped after car has been idle for x seconds. Used only in North American controllers with LCEADON board. See ADON setup guide 805463.
11	K637 Relay Test	0	0	0	0	1	0 = K637 relay normally controlled 1 = K637 relay manually energized	This function is used only for elevator inspections. For a stop switch over connect test, set this item to 1. This will hold the K637 in an energized state until the item is set back to 0 or the power is cycled.
12	Landing Display Type	1	1	1	0	1	0=use only basic SPI 1=use extended SPI	Allows downloading (5.7.1/2) of FCB software that can update old graphical displays DELEL and EP1.
13	Marine Settings	0	0	0	0	1	0= OFF 1=Marine Setting in use	Change standard IO and SPI & ACU messages for marine use. Select if SSM return drive and main indications is required.
14	Battery supervision disabled time	0	0	0	0	22	Time in hours	Battery test will be disabled for the time given by this parameter. Time to be left will be shown as follows: 0 = test is not disabled 1 = 10 s to 1 h 29 min 2 = 1 h 30 to 2 h 29 min . 22 = 21 h 30 min to 22 h

5 Commencing	Function	De-faultEU	De-faultNA	De-faultNC	Min	Max	Values	Description
20	ADON Setup	*	*	*	0	11	1 = Min Brake Decel - ch1 2 = Min Brake Decel - ch2 3 = Accum Start Distance - ch1 4 = Accum Start Distance - ch2 5 = Accum High Stop - ch1 6 = Accum High Stop - ch2 7 = Accum Low Stop - ch1 8 = Accum Low Stop - ch2 9 = SL1 Speed - ch2 10 = SL2 Speed - ch2 11 = Hysteresis - ch2	Elevator must be stopped for all other settings. Used in NA only. See ADON setup guide 805463.
21	ADON Encoder Type	1	1	1	1	5	1=OL35 Governor 2=OL100 Governor 3=Car Top Encoder 4=BAR Reader 5=Car Top Encoder GMP1.6	Elevator must be on inspection. Used in NA only. See ADON setup guide 805463.
22	Reserved							
23	ADON Low Speed Compare	0	0	0	0	1	0 = For contract speed of 0.75m/sec and higher. 1 = For contract speed of 0.5m/sec	For contract speed of 0.5m/sec., ADON software version 0.45 or higher must be used.
25	ADON Learn	0	0	0	0	1	0=No Action 1=Run ADON Learn	Must be on inspection. Used in NA only.
40	Set Zero Speed, Encoder	*	*	*	0	1	0=Original Board	Elevator must be stopped. Not used in NC.
41	Set NTS Flag	*	*	*	0	9	1 = View/Reset NTS Frequency Constant 2 = Reset NTS Fault 3 = Display Max Frequency seen since last clear 4 = Clear Max Frequency 5 = View/Reset NTS Percent Tolerance 9=Reset NTS Frequency Constant to Default	Elevator must be stopped. Not used in NC.

5	Commencing	Function	De-faultEU	De-faultNA	De-faultNC	Min	Max	Values	Description
	50	ETSL Total Number of Boards	0	0	0	0	5	Total number of ETSL boards in the shaft	Elevator must be stopped. After changing this parameter, before changing parameter 5-51, do power down. Not used in NC.
	51	ETSL Speed Setting	0	0	0	0	127	Speed Setting of the ETSL boards in m/sec	Elevator must be stopped. Number of ETSL boards must be > 0. Not used in NC. Displays & allows resetting of the speed setting of the ETSL rotary switches formatted as ONES.TENTHS meters/second The display value omits the decimal point, so that the displayed value is in tenths of meters/second. (Not used in NC) When entering menu 5-51, first select the board number, then you may choose the speed setting of that board.
	52	ETSL SETUP	0	0	0	0	1	0 = No Action 1 = Run ETSL Setup	Elevator must be stopped. Number of ETSL boards must be > 0. Not used in NC. Refer to EDMS document #804441H01 for the board setup procedure.
	53	ETSL Disable	0	0	0	0	1	0 = No Action 1 = Set the active value of the number of etsl board to 0 for the duration of this run. This is reset with a power cycle.	Does not change NVRAM stored value. Can be used in some test situations.

5	Commencing	Function	De-faultEU	De-faultNA	De-faultNC	Min	Max	Values	Description
									Elevator must be stopped. Power cycle before downloading to board. The speed step max value is essentially a speed filter. Occasionally the encoder will generate a noise value. If these inputs aren't filtered out, they will cause nuisance errors. This value limits how much two consecutive input speed values can deviate from each other. It is somewhat empirical & its value depends on the encoder type & the amount of vibration where the encoder is mounted, among other things. The default value is preferred. If random self-test failures and 221 errors occur, this is an indication that this value needs to be increased it is preferred to use the lowest value possible, established by trial & error. Not used in NC.
	54	ETSL Speed Step Maximum	450	450	450	149	700	Value set >149 will override the default calculation in etsl setup	
	55	ETSL Speed Step Maximum Download to Boards	0	0	0	0	1	0 = No Action 1 = Download ETSL Speed Step to Boards	Elevator must be stopped. ETSL must be in setup mode. Selecting 1 will cause a download of the speed step max value to the etsl boards. The same value goes to all etsl neurons. Not used in NC.
	56	Floor marking download	*	*	*	0	1	0 = No Action 1 = Download floor markings to COP	Floor marking download to COP. For PPC only.
	57	Keypad lock state	0	0	0	0	1	0 = Locked 1 = Open	Keypad lock state. If keypad is locked only FRD, PRC and FSC can enable keypad. If open then keypad is always enabled. For PPC only.
6	V3F25/18 or V3F16L or LCEDRV	See V3F25/18 or V3F16L or LCEDRV parameter document						See V3F25/18 or V3F16L or LCEDRV parameter document	V3F25/18 - Refer to 713983 V3F16L - Refer to 784393 LCEDRV - Refer to 713433

7 Elevator parameters	Function	De-fault EU	De-fault NA	De-fault NC	Min	Max	Values	Description
Door	1 Access Door Open	3	3	3	0	3	0 -- Rear door at top and bottom floors 1 -- Rear door at top, front door at bottom 2 -- Front door at top, rear door at bottom 3 -- Front door at top and bottom floors	Describes the door to be opened by HAS switches Notel Check also parameter 7.70.
	3 Close Fail Wait	30	30	30	10	99	Display * 100ms = internal value	Recovery Time for opening and closing fault
	4 Closing Limit	15	15	15	10	30	Display * 100ms = internal value	Defines the maximum door closing time
	5 Door Contact Supervision	*	*	*	1	2	submenu 1 = Shaft Door Contact submenu 2 = Car Door Contact	Submenu values: sub1: 0 = car door contact not supervised (default in V1,NC) 1 = car door contact supervised (default in NA) sub2: 0 = shaft door contact not supervised (default in V1,NC) 1 = shaft door contact supervised (default in NA)
	9 Door dir change	0	0	0	0	254	100ms	Minimum time to change door direction
	11 Separate Nudging Output	0	0	0	0	1	0 = OFF 1 = ON	
	12 HAC and Inspection Door Movement	1	1	1	0	1	0 = No automatic door movement allowed 1 = Door opens automatically with in-car Access switch, closes with inspect up/down	Defines the door behavior when in Hoistway Access mode or inspection drive.
	13 DSS Floor	0	0	0	0	4	0=Door speed selected based on Traffic 1=Low Speed (Opening and Closing) 2=Moderate Speed (Opening and Closing) 3=Normal Speed (Opening and Closing) 4=High Speed (Opening and Closing)	To select the door speed at all floors other than main floor

7	Elevator parameters	Function	De-fault EU	De-fault NA	De-fault NC	Min	Max	Values	Description
	Fire NA	28 FSC in use	0	0	0	0	1	0 = No Fire Status Control (FSC) board is connected to the controller. 1 = An FSC is connected to the controller.	A Fire Status Panel (FSP) normally contains one or more Fire Status Control (FSC) boards. However, an FSP can exist without FSC boards, and an FSC can exist without an FSP. This parameter disables or enables the supervision of the FSC board. If this parameter is set to 1, then parameter 7-44 (FRD 2nd Phase 1 Switch) should also be set to 1.
		29 Blank PI on FRD	0	1	0	0	1	0 = no blanking PI on FRD US 1 = blank PI on FRD US	0=normal display on FRD 1=blank display on other than FRD return floor
		30 Chicago Fire Group Hold	0	0	0	0	1	0 = OFF 1 = ON	Prevents cars in a group, returning from fire control to normal service, if any car is still on Fire Phase 2. Used in NA only.
		31 FRD Door Holding	0	0	0	0	1	0 = No Hold 1 = Hold at floor	Defines door operation after FRD car switch turned to OFF
		32 FRD Door Phase 1	0	0	0	0	3	0 = hold open 1 = Closed after predefined time, opening by a DOB 2 = Closed after predefined time, opening by a landing call 3 = Closed after predefined time. Opening by either DOB or landing call	Defines the door operation after phase 1 returning
		33 FRD Door Phase 1 Time	60	60	60	1	120	seconds [1 .. 120]	Defines the time to keep door open after phase-1 return in Denver and Houston fireman drive

7 Elevator parameters	Function	De-fault EU	De-fault NA	De-fault NC	Min	Max	Values	Description
							0 = hoistway recall machine room - No FRD 1 = hoistway recall machine room - No FRD 2 = hoistway recall machine room - No FRD 3 = hoistway recall machine room - No FRD 4 = hoistway recall machine room - No FRD 5 = hoistway recall machine room - No FRD 6 = hoistway recall machine room - No FRD 7 = hoistway recall machine room - No FRD 8 = hoistway recall machine room - No FRD	Defines the operations of hoistway and machine room smoke detectors for FRD Phase 1 recall. (MAIN = Fire floor, ALT = Fire Reserve Floor) Used in NA only.
34	FRD Flashing Recall	5	5	5	0	8		
36	FRD Mode Override Time	30	30	30	0	254	seconds [0 .. 254]	Time after current lift mode is turned to FRD Phase 1

7 Elevator parameters	Function	De- fault EU	De- fault NA	De- fault NC	Min	Max	Values	Description
37	FRD Remaining Phase 2	0	0	0	0	2	0 = Return Phase 1 1 = Cont. Phase 2 regardless if in-car switch is turned off 2 = Cont. Phase 2 until in-car switch is turned off at evacuation floor	Defines operation after FRD car switch turned to OFF
38	Smoke Detectors In Use	0	1	0	0	1	0 = Smoke Detectors not used 1 = Smoke Detectors used	Enable/Disable smoke detector reading
39	FRD Door Opening	2	2	2	1	4	1 = DOB Momentary 2 = DOB Continuous 3 = Auto Opening 4 = Keep Open By DOB (FRD Chicago)	Defines DOB operations during FRD Phase 2. Used in NA only.
40	FRD Door Closing	2	2	2	1	4	1 = DCB Momentary (FRD New York) 2 = DCB Continuous 3 = Car Call Momentary 4 = Car Call Continuous	Defines DOB operations during FRD Phase 2. Used in NA only.
41	FRD Priority	*	*	*	1	5	<u>Conditions:</u> submenu 1 = FRD overrides when doors closed submenu 2 = FRD overrides after wait time or when doors are closed <u>Modes:</u> submenu 3 = FRD overrides ATS submenu 4 = FRD overrides PRC submenu 5 = FRD overrides HEL	For each submenu, set to a value of 1 to select the option. First choose between submenu 1 or 2 to decide what conditions must be met for FRD to override the specified mode(s). Then set submenus 3,4, and/or 5 if FRD is to override the specified mode(s) .
42	Smoke Detector Latch	0	1	0	0	1	0 = Latch not in use 1 = Latch with momentary activation	Defines if smoke detectors signals latch. When set to 1, a momentary activation of smoke detectors will latch the signal
43	FRD A17 (2000)	1	1	1	0	1	0 = OFF 1 = ON	Defines the operation of Fire Service for A17 2000 Code

7 Elevator parameters	Function	De-fault EU	De-fault NA	De-fault NC	Min	Max	Values	Description
	FRD 2nd Phase 1 Switch	0	0	0	0	1	0 = 2nd Phase 1 switch not connected. 1 = Second Phase 1 switch connected to Fire Status Control (FSC) board or LCEOPT Board.	If an additional FRD Phase 1 switch is used and the elevator is at the Alternate Fire Recall Floor during fire service, then: A17.1-2000 Section 2.27.3.1.6(j) requires that both switches be ON for the elevator to recall to the Main Fire Floor. A17.1-1996 Section 211.3a(10) requires that only the main Phase 1 switch is required to recall the elevator to the Main Fire Floor. If an FSC is used then set UI-7-28 =1
Emergency	EPD Full Service Enabled	1	1	1	0	1	0 = Lift is not allowed to go to normal service on EPD 1 = Lift is allowed to go to normal service on EPD	Define if elevator is allowed to operate on normal service under emergency power with internal sequencer.
	EPD Full Service Permission	*	*	*	1	2	submenu 1 = enable full service in PRC Mode submenu 2 = enable full service in OSS Mode	Elevator modes allowed during EPD full service
	EPD Speed	0	0	0	0	2	0 = Full Speed 1 = Reduced Speed 2 = Reduced speed only during return drive	Defines speed during EPD
	EPD with Lockings	0	0	0	0	1	0 = Lockings bypassed 1 = Lockings not bypassed	Enable/Disable override of lockings in EPD
	Return Order	*	*	*	0	8	submenu 1 = 1st lift to return submenu 2 = 2nd lift to return ... submenu 8 = 8th lift to return	The order in which the elevators are returned to the emergency return floor. A submenu value of 0 means not in use 1,2,3, ... 8 is the lift number. Each submenu shall be given a different value, or 0.
	Max No of Returning	1	1	1	0	8	# of lifts	Defines the number of elevators which can return simultaneously on EPD, and the number of elevators that can simultaneously operate on full service EPD.
	Power Up Delay	0	15	0	0	255	0 = External Sequencer used 0 > value < 255, Internal Sequencer used, set min. 15 as a default 255 = RESQPAK	Power Up Delay for internal emergency power sequencer

7	Elevator parameters	Function	De-fault EU	De-fault NA	De-fault NC	Min	Max	Values	Description
52	In Use Order	*	120	120	*	0	8	submenu 1 = 1st lift available for full service	After the elevators have returned to the emergency return floor, the order in which they can be put into full service, is determined by this sequence
								submenu 2 = 2nd lift available for full service	
53	Return Supervision Time	120	120	120	0	255	seconds	submenu 8 = 8th lift available for full service	Time to get elevator returned to evacuation floor
								seconds	
54	Running Supervision Time	15	15	15	10	254	seconds		Time to get elevator started in emergency power
FRD	Fire Service Access Level	1	1	1	**	**	Floor number		Only for EN81-72. Fireman's Drive (FRD) phase one Fire Service Access floor.
EN81-72	Fire Service Access Side	1	1	1	1	2	1=A-door, 2=B-door		Only for EN81-72. Defines how doors of Fire Service Access floor will stay after FRD phase one return drive.
Misc	MES Enabled	0	0	0	0	1	0 = OFF 1 = ON		Enable/Disable Medical Emergency Service. Used in NA only.
61	MES Floor	0	0	0	0	**	0 = Return Floor and side read from LCEFCB board message bottom floor to top floor = Return floor for MES option		Return Floor for Medical Emergency Service. Used in NA only.
62	MES Side	1	1	1	1	3	1 = Front Door 2 = Rear Door 3 = both doors		Door to be opened after Medical Emergency Service recall. Used in NA only.
63	High Rise Arrow In Use	0	0	0	0	1	0 = Not In Use 1 = Is In Use		Special "big" arrows are in use in high rise installation.
67	Start/hour limit value	0	0	0	0	140	Start/hour limit value 10 start steps.	When this limit values is exceeded door times are extended. Used in NA only.	
							Possible values:0,60,70,80,90,100,110,120,130,140		
68	HAC Car Top Access Zone	25	25	25	10	40	HAC Car Top Zone in meters	Hoistway access to car top zone length, the distance the car can be driven downwards from HAC floor with HAC landing key switch. Used in NA only.	

7	Elevator parameters	Function	De-fault EU	De-fault NA	De-fault NC	Min	Max	Values	Description
69		HAC Pit Access Zone	25	25	25	10	40	HAC Pit Zone in meters	Hoistway access to pit zone length, the distance the car can be driven upwards from bottom floor with HAC landing key switch. Used in NA only.
70	Misc	HAS Upper floor	0	0	0	0	**	0 = HAS does not exist 1 = top floor = HAS upper floor	Defines the upper floor for Hoistway Access Function. Used in NA only.
71		K486 (SL1) Drop Window	0	0	0	0	255	cm/sec	Speed added to 75 cm/sec before supervising that K486 has dropped. Used in NA only.
72		DTS test time	40	40	40	1	100	Seconds	Defines the maximum floor to floor drive time. NOTE! Do not touch if you don't know what you are doing. NOTE! Doesn't work with KDH or R100 drives.
73		Try Limit	5	3	5	1	5	5 for Canada	Defines number of start attempts
74		BPI in use	0	0	0	0	2	0 = OFF 1 = ON 2 = BPI A	Enable/Disable ByPass Indication feature
75		Resume 512 Type	0	0	0	0	1	0 = Lock out elevator after two consecutive faults 1 = Lock out elevator after first fault	Defines number of times door zone circuit supervision faults before lift is shut down
76		DAL Time	0	0	0	0	120	0 = Reset Manually. (Seconds)	Timeout to reset disturbance alarm.
77		DAL Type	0	0	0	0	1	0 = DAL G 1 = DAL CA (DAL for Canada)	Define the operation type of Disturbance Alarm Output
78		V2 Drive In Use	0	0	0	0	0		Combined with Menu 1-95.
79		External Gong	0	0	0	0	1	0 = OFF 1 = ON	When set to ON, LCECOB24 becomes a gong output instead of HEL
84		Car Position Triggering	0	0	0	0	1	0 = display advance position 1 = display actual position	Landing and car displays show either advanced position or actual position.
85		NSS delay	0	0	0	0	10	Seconds [0 .. 10]	Defines delay to avoid simultaneous start in a group
86		FPO Delay	30	30	30	0	60	Seconds [0 .. 30]	The release time after last call of the FPO lift

7 Elevator parameters	Function	De-fault EU	De-fault NA	De-fault NC	Min	Max	Values	Description
87	FPO type	0	0	0	0	3	0 = FPO OFF 1 = FPO C (With Normal Calls) 2 = FPO C (With Special Calls) 3 = FPO A (Automatic with Special Calls)	1 - FPO C - FPO Continuous with normal calls. 2 - FPO C - FPO Continuous with special calls. This function is activated by a time clock or a manual switch. The elevator will stay in FPO as long as the activation signal is "ON". 3- FPO A - FPO Automatic This function is activated automatically when an FPO call appears. The elevator will automatically revert back to normal group operation 'n' seconds (determined by FPO Delay parameter 7-86) after the last FPO call was served.
88	F2K display fields car	*	*	*	1	8	submenu 1 = 1st field submenu 2 = 2nd field submenu 3 = 3rd field submenu 4 = 4th field submenu 5 = 5th field submenu 6 = 6th field submenu 7 = 7th field submenu 8 = 8th field	0 = OSI indication 1 = FRD indication 2 = OLF indication 3 = PRC indication 4 = LOC indication 5 = ATS indication 6 = HEL indication 7 = EAQ indication
89	F2K display fields landing	*	*	*	1	7	submenu 1 = 1st field submenu 2 = 2nd field submenu 3 = 3rd field submenu 4 = 4th field submenu 5 = 5th field submenu 6 = 6th field submenu 7 = 7th field	0 = OSI indication 1 = PRC indication 2 = FRD indication 3 = HEL indication 4 = ATS indication 5 = BPI indication 6 = LOL indication
90	Fast Start Sequence	0	1	0	0	3	0 = OFF (No Cabinet elevators) 1 = Separate Door Close Limit in use 2 = Drive command to drive in advance 3 = Fast Start Sequence (1+2)	Enables/disables fast start sequence

Submenu 1: [0,1,2,3] = option board 0 exists for A side = 1, C side = 2, both sides = 3
 Submenu 2: [0,1,2,3] = option board 1 exists for A side = 1, C side = 2, both sides = 3
 Submenu 3: [0,1,2,3] = option board 2 (lockings node for floors 1-8) exist for A side = 1, C side = 2, both sides = 3
 Submenu 4: [0,1,2,3] = option board 3 (lockings node for floors 9-16) exist for A side = 1, C side = 2, both sides = 3
 Submenu 5: [0,1,2,3] = option board 4 (lockings node for floors 17-24) exist for A side = 1, C side = 2, both sides = 3
 Submenu 6: [0,1,2,3] = option board 5 (lockings node for floors 25-32) exist for A side = 1, C side = 2, both sides = 3
 Submenu 7: [0,1,2,3] = option board 6 (lockings node for floors 33-40) exist for A side = 1, C side = 2, both sides = 3
 Submenu 8: [0,1,2,3] = option board 7 (lockings node for floors 41-48) exist for A side = 1, C side = 2, both sides = 3
 Submenu 9: [0,1,2,3] = option board 8 (lockings node for floors 49-56) exist for A side = 1, C side = 2, both sides = 3
 Submenu 10: [0,1,2,3] = option board 9 (lockings node for floors 57-63) exist for A side = 1, C side = 2, both sides = 3
 Submenu 11: [0,1] = option board A (fire protection door node for floors 1-8) exists
 Submenu 12: [0,1] = option board B (fire protection door node for floors 9-16) exists
 Submenu 13: [0,1] = option board C (fire protection door node for floors 17-24) exists
 Submenu 14: [0,1] = option board D (fire protection door node for floors 25-32) exists
 Submenu 15: [0,1] = option board E (fire protection door node for floors 33-40) exists
 Submenu 16: [0,1] = option board A (jumper J9 = rear, fire protection door node for floors 41-48)
 Submenu 17: [0,1] = option board B (jumper J9 = rear, fire protection door node for floors 49-56)
 Submenu 18: [0,1] = option board C (jumper J9 = rear, fire protection door node for floors 57-63)
 Submenu 19: [0,1] = option board D (jumper J9 = rear, freight door control node for freight elevators)
 Submenu 20: [0,1] = option board E (jumper J9 = rear, freight door control node for freight elevators)
 Submenu 21: [0,1,2,3] = option board F (PAD,CSM,RES,FRE,OIL monit. for NA) exist for A side = 1, option board F (FRD KR secondary phase for ROW) exist for C side = 1, both sides = 3

Submenu 1: [0,1,2,3]
 Submenu 2: [0,1,2,3]
 Submenu 3: [0,1,2,3]
 Submenu 4: [0,1,2,3]
 Submenu 5: [0,1,2,3]
 Submenu 6: [0,1,2,3]
 Submenu 7: [0,1,2,3]
 Submenu 8: [0,1,2,3]
 Submenu 9: [0,1,2,3]
 Submenu 10: [0,1,2,3]
 Submenu 11: [0,1]
 Submenu 12: [0,1]
 Submenu 13: [0,1]
 Submenu 14: [0,1]
 Submenu 15: [0,1]
 Submenu 16: [0,1]
 Submenu 17: [0,1]
 Submenu 18: [0,1]
 Submenu 19: [0,1]
 Submenu 20: [0,1]
 Submenu 21: [0,1,2,3]

LCEOPT
 supervision

91

7

21

1

*

*

*

7 Elevator parameters	Function	De-fault EU	De-fault NA	De-fault NC	Min	Max	Values	Description
92	Lanterns at Landing	3	3	3	0	5	0 = LAL SB 1 = LAL SN 2 = LAL DB 3 = LAL DN 4 = LAL AB 5 = LAL AN	<p>LAL Subcode 1: D = Lanterns ON at deceleration point S = Lanterns ON when stopping at landing A = Lanterns FLASH(Advance Signalling) LAL Subcode 2:(Non-Terminal Floors Only) B = If no further calls, both Lanterns ON N = If no further calls, both Lanterns OFF Note: On terminal floors, lantern will light in proper direction when there are no further calls</p>
93	Lanterns In Car	1	1	1	0	2	0 = LAC SB 1 = LAC SN 2 = blinking position indicator	<p>S = Lanterns ON when stopping at landing LAC Subcode 2:(Non-Terminal Floors Only) B = If no further calls, both Lanterns ON N = If no further calls, both Lanterns OFF Note: On terminal floors, lantern will light in proper direction when there are no further calls Choise 2 is for HAN KR feature</p>
94	WSC M	1	1	1	0	2	0 = OFF, 1 = normal, 2 = fail safe for marine	Use 2 for marine fail safe which returns to OSS return floor
95	PRL M & HEL M waiting time	0	0	0	0	30	0 = 30 sec, 30 = 900 sec.	Marine environment waiting time for keeping PRL or HEL mode active. Step is 30 sec.
96	PRL indication type	0	0	0	0	1	1 = flashing HEL indication	HEL indication flashes in car and landing displays
97	OSS LCN operation	0	0	0	0	1	1 = OSS LCN in effect	OSS LCN = OSS in main floor turns off all indications at landings
98	EID type	0	0	0	0	6	0 = EID P 1 = EID B 2 = EID C 3 = EID D 4 = EID E 5 = EID F 6 = EID G	<p>P = Passive, nameplate or sign only B = Active, Identifier blinking C = Active, Identifier on D = Active, identifier blinking, on at deceleration point E = Active, identifier on at deceleration point F = Active, identifier blinking at deceleration point G = Active, identifier on Note! For PPC only.</p>

7	Elevator parameters	Function	De-fault EU	De-fault NA	De-fault NC	Min	Max	Values	Description
		99 Site Specific Software Control	0	0	0	0	7	0 = No site specific software control. 1 = reserved 2 = reserved 3 = Low Oil Protection for Los Angeles 4 = Massachusetts EPD 5 = Indian display interface 6 = Detroit Heat Sensor Operation 7 = Hall gongs follow hall lanterns	This value is used to identify custom designed software for a specific job site.
8	External Group Parameters	Function	De-fault EU	De-fault NA	De-fault NC	Min	Max	Values	Description
	CPS	1 Subzone Options	1	1	1	1	5	Submenu 1 = CPS option activation Submenu 2 = serve up / down calls Submenu 3 = up peak detection Submenu 4 = down peak detection Submenu 5 = CPS automatic	Defines CPS options
		2 Subzone floor low	0	0	0	0	**	CPS zone lowest floor	Defines the lowest floor of CPS zone
		3 Subzone floor high	0	0	0	0	**	CPS zone highest floor	Defines the highest floor of the CPS zone
		4 Lowest entrance floor	0	0	0	0	**	The lowest entrance floor in the building	The lowest entrance floor in the building
		5 Highest entrance floor	0	0	0	0	**	The highest entrance floor in the building	The highest entrance floor in the building
	SGO	6 SGO type	0	0	0	0	2	0 = no Split Group opration 1 = SGO N, separate riser for Split Group elevators 2 = SGO P, parallel risers for Split/Normal Group elevators	Split Group Operation type

8	External Group Parameters	Function	De-fault EU	De-fault NA	De-fault NC	Min	Max	Values	Description
		19 Full DCS RollCall	0	0	0	0	1	0=Normal RollCall 1=RollCall based strictly on .dcf file	Select RollCall type for DCS environments. For PPC only.
	Group	20 Car size	13	10	13	1	99	The capacity of the car in persons	The capacity of the car
		21 Running speed	10	10	10	5	100	The speed of the elevator in 0.5m/s steps	The speed of the elevator
		22 Peak Load Up	60	60	60	10	99	% of capacity	Peak load up % limit can be adjusted here. Used in IUP and NEX features.
		23 Traffic Forecaster (TF) in use	0	0	0	0	1	0= Traffic Forecaster Disabled 1= Traffic Forecaster Enabled	To enable / disable Traffic Forecaster (TF) feature in KGC

Appendix 3 – LCE fault codes

For technical assistance please contact your Regional KONE Office. For contact details, see www.kone.com

Reference: KONE Drawing 81.3138 2006-11-28.

Fault Code	Description	Fault Code	Description	Fault Code	Description	Fault Code	Description
00 01	Drive time supervision elapsed	00 42	Car light supply supervision	00 76	553 relay in door zone supervision circuit did not work OK - first occurrence. If failed on two consecutive drives a fault 14 will be reported.	01 49	V2: 77:U missing
00 01	Drive time supervision elapsed (Resolve 20)	00 43	Close door limit missing	00 77	Door open limit continuously inactive	01 50	NTS invalid switch fault Does not apply to KCM831 hydro and ReSolve 20.
00 03	Overspeed	00 44	Door closing failed too many closing trials	00 78	Stuck car call	01 51	V1 NTS faulty switch Does not apply to KCM831 hydro and ReSolve 20.
00 04	Synchronization failed on three consecutive drives	00 46	Car door contact, hall door contact or close limit do not match	00 79	Stuck landing call	01 52	V1 NTS Stopping fault Does not apply to KCM831 hydro and ReSolve 20.
00 07	Door zone switch 30 or B30 stuck	00 48	Reopen device active longer than 1 minute	00 80	Lock check (553) circuit failed	01 53	V2: NTS deceleration Relates to LCEDRV products.
00 12	Anticreep not released for two consecutive drives (hydraulic lift)	00 50	Anticreep is not released for the first time (hydraulic lift)	00 81	Releveling failed	01 54	Invalid NTS switch combination Relates to LCEDRV products. 77U active in down direction; 77N active in up direction.
00 13	Anticreep not energised for two consecutive drives (hydraulic lift)	00 51	Start failed	00 82	Incorrect door zone supervision circuit operation - first occurrence. If failed on two consecutive drives a fault 15 will be reported.	01 56	Either 77:FU or 77:FN active.
00 14	553 relay in door zone supervision circuit did not operate during two consecutive drives. This fault follows fault 76.	00 52	Top and bottom synchronization switches active simultaneously	00 83	Position lost	01 63	K486 relay failed to drop.

Fault Code	Description	Fault Code	Description	Fault Code	Description	Fault Code	Description	Fault Code	Description
00 15	Incorrect door zone supervision circuit operation during two consecutive drives. This fault follows fault 82.	00 56	Positive pressure switch (PPS) activated Applies to KCM831 hydro only.	00 84	Door open limit continuously active. At least one of the door close limits is active together with the door open limit within certain time.	01 64	K486 failed to pick when car is stopped.		
00 19	Cylinder limit switch supervision for hydraulic lifts	00 58	Non drive time out	00 85	Door opening prevention switch turned ON	01 65	Hydraulic oil level too low		
00 21	Safety circuit broken. For NA this fault has sub codes starting with 21 00, as described below.	00 59	Anti-creep is not energised for the first time (hydraulic lift)	00 86	Start permit continuously ON (Not detected with V3F drives. Fault 25 detected instead).	01 66	Releveling too fast. Valid only for traction products.		
00 22	Shaft door contact opened during drive	00 61	Nudging taken too long	00 87	Car door contact does not open.	01 67	Hydraulic oil temperature too high		
00 23	Car door contact opened during drive	00 62	Inspection direction buttons stuck on.	00 89	DOM supervision failed	01 68	Hydraulic oil temperature too low		
00 25	Start permit fault	00 63	not used.	00 91	BAR ChA, ChB, ChC (30) or B30 failure	01 69	The automatic battery test has detected low battery.		
00 26	Drive not OK	00 64	K637 relay feedback failure	00 92	BAR ChA, ChB cross wired or 77 wrong polarity	01 70	AC supply voltage failed		
00 27	K7 (main relay) relay stuck ON	00 65	Normal relay (K442) on LCEADON failed to pick.	00 93	Normal relay (K442) on LCEADON failed to drop.	01 72	24 VDC car or shaft supply power.		
00 28	Swing door safety ray broken	00 66	HAS relay (K442:1) on LCEADON board failed to drop while NOT in inspection mode.	00 95	Hall door contact does not open.	01 73	Hydraulic oil level sensor failure		
00 29	A door became fully open before the car reached ACL.	00 67	Fault not Active. HAS relay (442:1) on LCEADON board failed to pick while in HAS.	00 96	Car door limit does not open	01 74	Hydraulic oil temperature sensor failure		
00 36	Main contactor released during drive	00 71	30 or B30 (door zone) missing	00 97	K616 relay failed to drop	01 75	ETS up (136:U) switch failed		
00 37	Brake open fault	00 72	61:U input stuck fault	00 98	K616 relay failed to pick	01 76	ETS down (136:N) switch failed		
00 38	Main brake module feedback fault for ADON2	00 73	61:N input missing	01 45	EBD device failed	01 77	ADON channel 1 detects overspeed governor trip		
00 39	77:U, 77:N bypass button stuck	00 74	61:N input stuck fault	01 46	EBD battery failed	01 78	ADON channel 2 detects overspeed governor trip		
00 41	Emergency Brake failed to pick	00 75	61:U input missing	01 48	V2: 77:N missing	01 79	ADON channel 1 detects unintended movement.		
01 80	ADON processor 2 detects unintended movement.	02 10	Car Light Failure (KRM)		DRIVE FAULTS		DRIVE FAULTS DURING SETUP		

Fault Code	Description	Fault Code	Description	Fault Code	Description	Fault Code	Description	Fault Code	Description
01 81	ADON2 processor 1 detects loss of 24Vdc or 230Vac power.	02 11	Inaccurate stopping (KRM)	01 01	Drive stop	01 11	Vane 61:N below 61:U		
01 82	ADON2 processor 1 detects loss of 24Vdc or 230Vac power.	02 12	Uncontrolled movement detected (KRM)	01 02	RMS overcurrent	01 12	61:U/N overlap too small		
01 83	Relay K464:2 is not in the same state as K464:1.	02 13	No floor nodes found.	01 02	LCEDRV buffer test button stuck	01 13	Synchronize (77:S) switch error		
01 84	Relay K464:1 is not in the same state as K464:2.	02 14	Failure of K1 or K2 relay check on ETSL board.	01 03	Braking resistor	01 14	Floors too close		
01 85	ADON channel 1 detects K464:1 relay failed	02 15	Current detection failure	01 04	Motor too hot	01 15	Scaling error		
01 86	ADON channel 2 detects K464:2 relay failed	02 16	Speed comparison Test Failure	01 04	Motor too hot	01 16	Wrong top floor count		
01 87	LCEADON channel 1 detects Ebrake/Rope gripper failed to pick.	02 17	LCEETSL emergency terminal speed limiting event This event is the purpose of the ETSL board.	01 05	Problem in AC voltage	01 17	Drive has no setup		
01 88	LCEADON channel 2 detects Ebrake/Rope gripper failed to pick	02 18	Setup Jumper Moved	01 05	V3F10 is faulty				
01 89	LCEADON channel 1 detects Ebrake/Rope gripper failed to drop	02 19	Startup Error	01 06	Inverter not ok				NODE FAULTS
01 90	LCEADON channel 2 detects Ebrake/Rope gripper failed to drop	02 20	Need ETSL Setup	01 06	Internal LCEDRV board fault	11 01	LCE can't see car Top cross connection board		
01 91	ADON processor 1 assist main brake.	02 21	Unreasonable speed change detected	01 07	LWD fail	12 nn	LCE can't see COP nn front extension board		
01 92	ADON processor 2 assist main brake	02 22	Overvoltage Error	01 07	LWD fail	22 nn	LCE can't see COP nn rear extension board		
01 93	LCEADON channel 1 detects sliding distance exceeded parameter UI 5-20-5 value	02 23	Board Missing	01 08	Motor/Tacho fault	13 01	LCE can't see front side car operating panel board		
01 94	LCEADON channel 2 detects sliding distance exceeded parameter UI 5-20-6 value	02 24	Scale Mismatch	01 09	Position lost	23 01	LCE can't see rear side car operating panel board		
01 95	LCEADON channel 1 detects sliding distance exceeded parameter UI 5-20-7 value	02 25	Relay Test Failed to run	01 09	Position lost	14 nn	LCE can't see nn floor front side control board		
01 96	LCEADON channel 2 detects sliding distance exceeded parameter UI 5-20-8 value	02 26	Encoder pulses missing	01 10	Heatsink prevents start	24 nn	LCE can't see nn floor rear side control board		

Fault Code	Description	Fault Code	Description	Fault Code	Description	Fault Code	Description	Fault Code	Description
01 97	LCEADON speed inequality with channel 2	02 27	ETSL (136:LX/Nx) Switch Failure	01 22	Drive time supervision	15 nn	LCE can't see nn floor front side control option board (FOB)		
01 98	LCEADON speed inequality with channel 1	02 29	The Doors Nearly Closed Input is On too early while doors closing.	01 25	Torque limit exceed	25 nn	LCE can't see nn floor rear side control option board (FOB)		
01 99	LCEADON channel 1 is using eeprom defaults	02 30	The Doors Nearly Closed Input is stuck ON.	01 26	Safety relay (fast start) is open	16 01	LCE can't see Gateway board		
02 00	LCEADON channel 2 is using eeprom defaults	02 31	The Doors Nearly Closed Input failed to turn ON.	01 27	Main contactor failure (fast start).	17 nn	LCE can't see nn option board		
02 01	LCEADON channel 1 system fault	02 32	The Doors Fully Closed Input is stuck ON.	01 28	LWD setup not done	27 nn	LCE can't see nn option board		
02 02	LCEADON Channel 2 system fault	02 33	The Doors Fully Closed Input failed to turn ON.	01 30	3rd party drive internal fault For MCU with AB DC drive, refer to 804612 For MCU and Yaskawa G5 drive, refer to Makes a correction drive to nearest floor and runs to bottom floor. This operation is repeated if fault condition is not cleared and lift in the 77U region. For DCBH and ABB drive, refer to Makes a correction drive to nearest floor and runs to bottom floor. This operation is repeated if fault condition is not cleared and lift in the 77U region. For V3F16L drive refer to 804611	18 01	LCE can't see front side car interface board		
02 03	LCEADON channel 1 communication failure	02 34	GLA, GLB, CGA or CGB relays are in wrong state.	01 31	MCU - drive, communication For MCU with AB DC drive, refer to XXXXXX For MCU and Yaskawa G5 drive, refer to XXXXXX For DCBH and ABB drive, refer to XXXXXX For V3F16L drive refer to XXXXXX	28 01	LCE can't see rear side car interface board		
02 04	LCEADON channel 2 communication failure	NTS-BAR				19 01	Fire Status Controller		

Fault Code	Description	Fault Code	Description	Fault Code	Description	Fault Code	Description
02 05	ADON software version in Channel 1 is different than in Channel 2	02 35	NTS test failed			34 00	Emergency Battery Drive interface. Without card information, used only in software
02 06	ADON software version in Channel 2 is different than in Channel 1	02 36	NTS trip event occurred			34 01	Emergency Battery Drive interface
02 07	LCECPU/LCEADON ID mismatch.	02 37	NTS warning event occurred			35 nn	LCE can't see nn display board
02 08	LCEADON PARAM jumper still in "SET" position.	02 38	NTS bypass event occurred			36 nn	LCE can't see nn landing call option node.
02 09	Elevator cannot run (KRM)	02 39	NTS tape missing			46 nn	LCE can't see nn landing call option node B side.

www.up-lift.cn